

SONESSE® ULTRA 50 DC HARDWARE SYSTEMS - ZMC

STANDARD BRACKET COMPONENTS

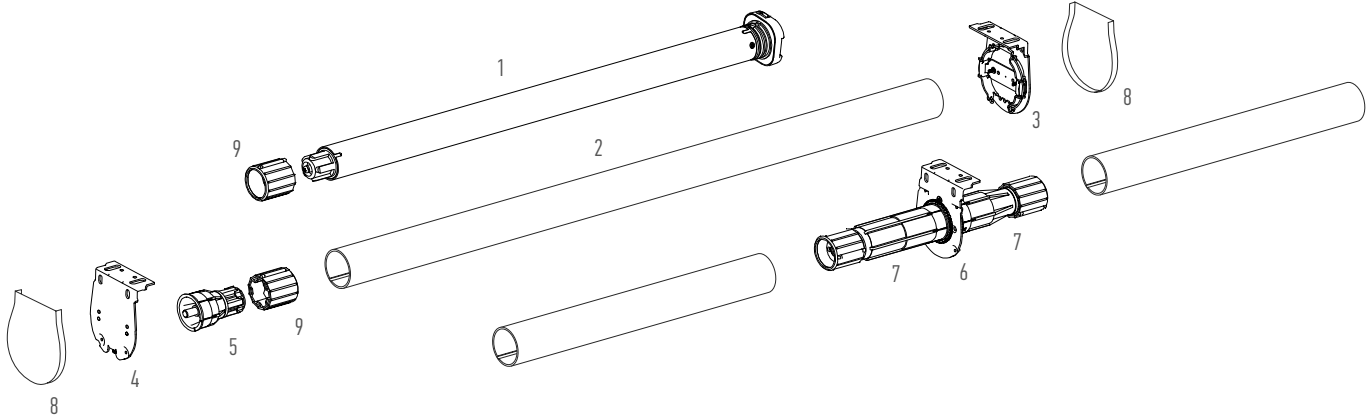

DIMENSIONS AND LIGHT GAP SPECIFICATIONS

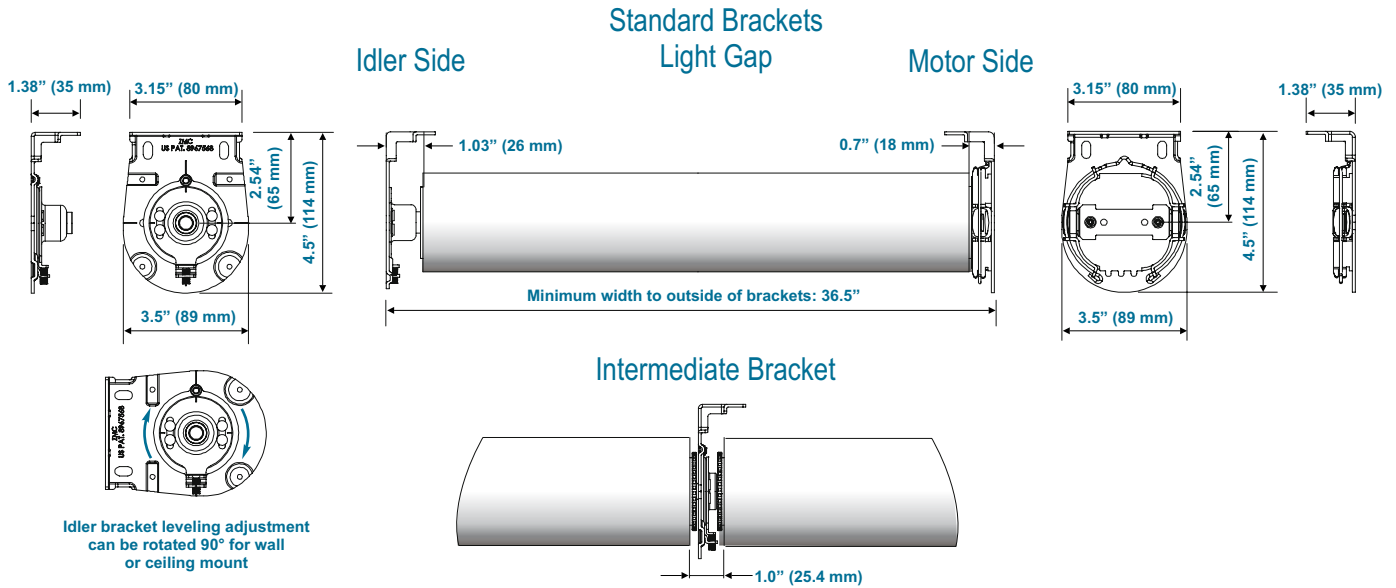

PRODUCT CHART

IMAGE	DESCRIPTION	CATALOG NUMBER
1	SONESSE® ULTRA 50 DC MOTOR (RTS) #1134023, RS485 #1134022	
2	ZMC 2" GROOVED MOTOR TUBE (PER FOOT)	9020965
3	SONESSE® ULTRA 50 DC MOTOR BRACKET WITH SPRING RING	9020957
4	SONESSE® ULTRA 50 DC IDLER BRACKET (10 MM BALL) (ADJUSTABLE WALL OR CEILING MOUNT)	9020958
5	SONESSE® ULTRA 50 DC UNIVERSAL SHORT IDLER END (10 MM)	9020959
6	SONESSE® ULTRA 50 DC INTERMEDIATE BRACKET (10 MM) (ADJUSTABLE WALL OR CEILING MOUNT)	9020961
7	SONESSE® ULTRA 50 DC INTERMEDIATE AND INDEXABLE COUPLER (10 MM SHAFT)	9020962
8	SONESSE® ULTRA 50 DC MOTOR AND IDLER BRACKET COVER	9020963
9	ZMC 2" GROOVED TUBE DRIVE WHEEL FOR SONESSE® ULTRA 50 MOTORS	9020964

SONESSE® ULTRA 50 DC HARDWARE SYSTEMS - ZMC

STANDARD AND ROLLER TUBE ACCESSORIES

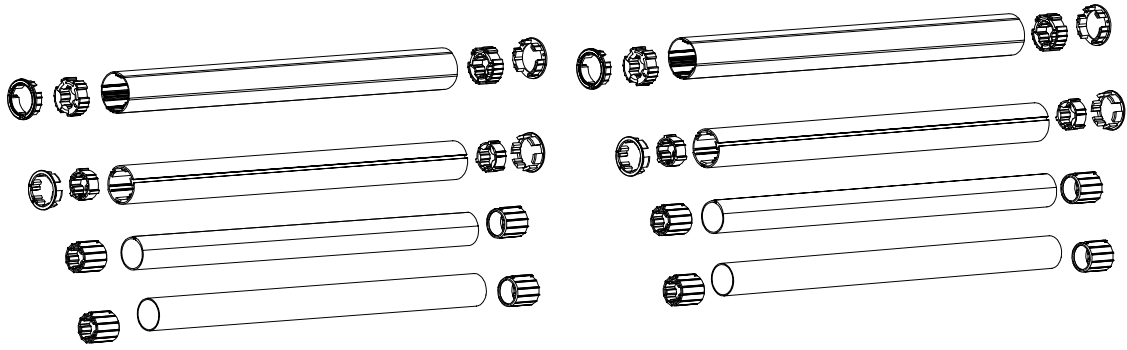

MOTOR BRACKETS AND ACCESSORIES FOR SONESSE ULTRA 50 DC MOTORS

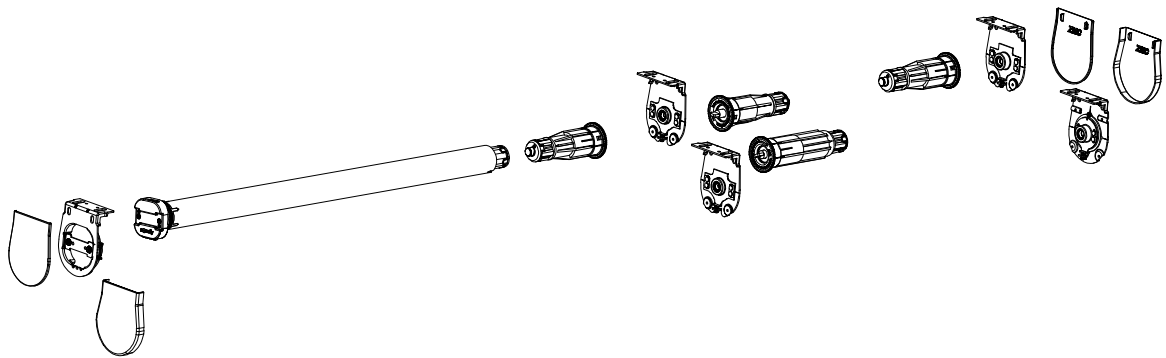

MOTOR U-JOINT INDEXABLE BRACKET FOR SONESSE ULTRA 50 DC MOTORS

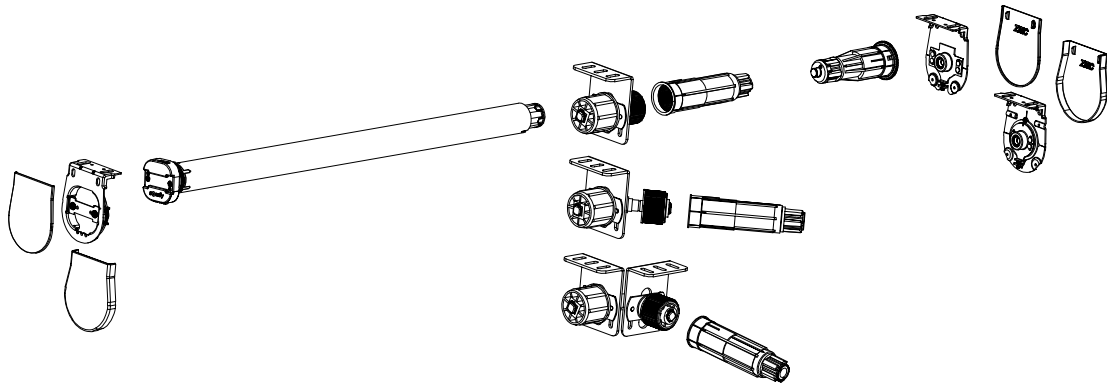

4" ADJUSTABLE U-JOINT INDEXABLE FASCIA BRACKET FOR SONESSE ULTRA 50 DC MOTORS

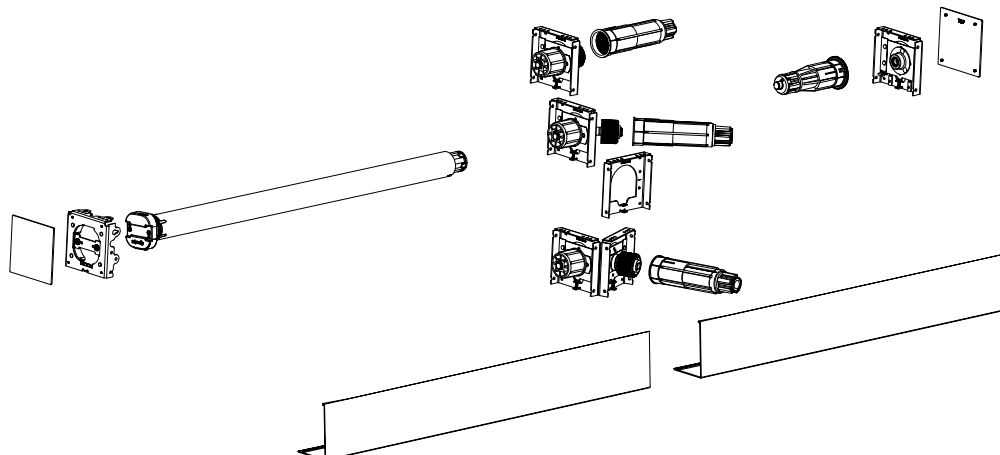

SONESSE® ULTRA 50 DC HARDWARE SYSTEMS - ZMC

4" FASCIA BRACKETS FOR SONESSE ULTRA 50 DC MOTORS

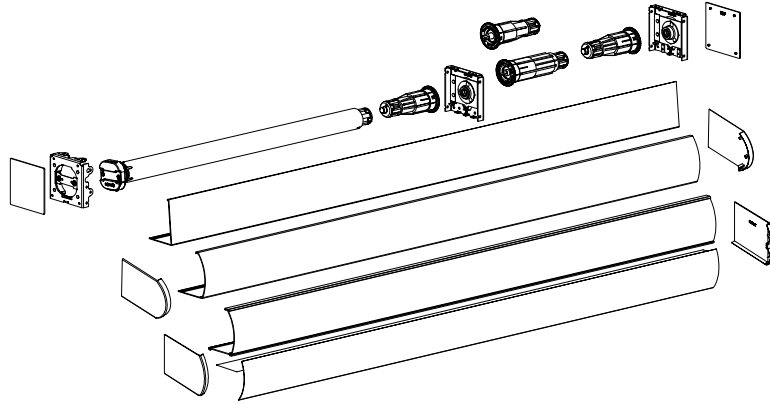

5.5" FASCIA SYSTEM FOR SONESSE ULTRA 50 DC MOTORS

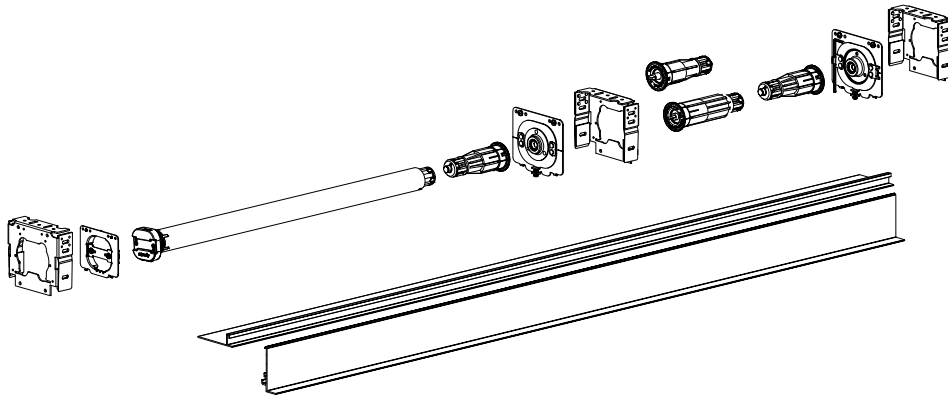

7.5" OPEN ROLL DUO BRACKET FOR SONESSE ULTRA 50 DC MOTORS

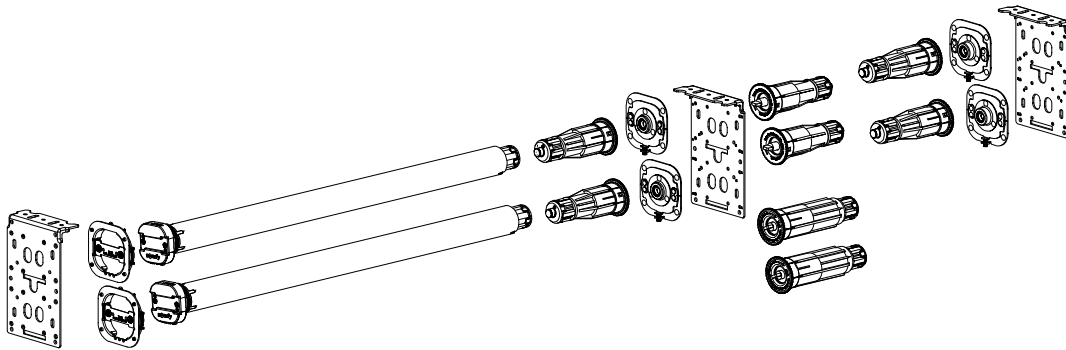

7.5" OPEN ROLL SINGLE BLIND BRACKET FOR SONESSE ULTRA 50 DC MOTORS

